

Chanson En Crochet

Design by Mari Lynn Patrick



Carol Kaplan

Mari Lynn Patrick begins this capelet with a simple crocheted chain for the neck edge. Then she has fun by working unusual crochet stitches in bands of lacy texture that fall gracefully over the shoulders. Don't be intimidated by the changing stitches—each one is clearly explained. The increases that shape the capelet are worked as an integral part of each stitch pattern, so the circumference grows with each pattern band. A row of picots around the neck and lower edgings, and a showy vintage button, add the finishing touches.

★ FINISHED SIZE:

54½" (138.5 cm) circumference at lower edge, 26" (66 cm) circumference at neck, and 12" (30.5 cm) long, including edging picots.

YARN:

About 412 yd (377 m) of worsted-weight (Medium #4) yarn. *We used:* Tahki New Tweed (70% merino wool, 15% silk, 11% cotton, 4% viscose; 103 yd [94 m]/50 g): #018 blue tweed, 4 balls.

★ HOOK:

Size J/10 (6 mm). Adjust hook size if necessary to obtain the correct gauge.

★ NOTIONS:

Tapestry needle; one 1" (2.5-cm) button.

★ GAUGE:

13 sc = 4" (10 cm) in single crochet.

★ SKILL LEVEL:

Intermediate. 

★ STITCH GUIDE:

Dc2tog: Work 1 dc, but do not draw yarn through last 2 loops on hook—2 loops on hook. Work the next dc until 1 loop rem, yo, and draw through all 3 loops on hook—1 dc dec'd.

Puff Stitch: All in same st: [yo, insert hook into st and draw up a loop] 4 times, yo and draw through all 9 loops on hook, work a tight ch 1 to close puff st.

Cluster-3: All in same st: [yo hook twice, insert hook in st, yo hook and draw through a loop, yo hook, draw through 2 loops, yo hook, draw through 2 loops] 3 times, yo hook, draw through 4 loops on hook.

Double Cluster-3: All in same st: cluster-3 (see above), ch 3, cluster-3.

★ CAPELET:

Ch 86—chain should measure about 26½" (67.5 cm) long.
Work scallop patt as foll:

Row 1: (RS) Sc in second ch from hook, then sc in each ch to end, turn—85 sc.

Row 2: (WS) Ch 1, sc in first sc, ch 2, skip 2 sc, sc in next sc, *skip 2 sc, 6 dc all in next sc, skip 2 sc, sc in next sc, ch 2, skip 2 sc, sc in next sc; rep from * 8 more times, turn.

Row 3: Ch 1, sc in first sc, ch 2, * dc in next dc, [ch 1, dc in next dc] 5 times, sc in next ch-2 space; rep from * 8 more times, ending last rep by omitting the sc in next ch-2 space, and working (ch 2, 1 sc) in last sc instead, turn.

Row 4: Ch 3 (counts as dc), [dc in next dc, ch 2] 5 times, *dc2tog (see Stitch Guide), ch 2, [dc in next dc, ch 2] 4 times, rep from * 7 more times to last dc, dc in next dc until 2 loops rem on hook, dc in last sc until 3 loops rem on hook, yo and draw through all 3 loops, turn.

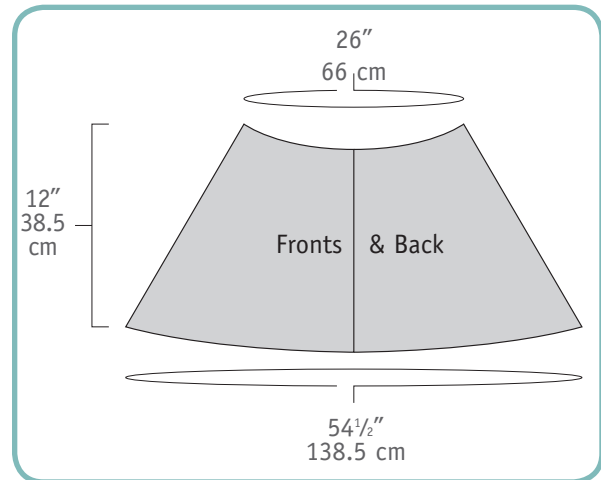

Row 5: Ch 1, 2 sc in first st, *[2 sc in ch-2 space, sc in dc] 4 times, 2 sc in ch-2 space, 2 sc in top of dc2tog; rep from * 8 more times, ending last rep with 2 sc in last st, turn—146 sc.

Row 6: Ch 3 (counts as dc), skip first sc, dc in each sc to end, turn—146 dc.

Cont in puff st patt as foll:

Row 7: Ch 1, sc in each of first 2 dc, *ch 3, skip 2 dc, puff st (see Stitch Guide) in next dc, ch 3, skip 2 dc, sc in next dc; rep from * to last dc, sc in last dc and sc in third ch of ch-3 at end of row, turn.

Row 8: Ch 5 (counts as dc, ch 2), work 3 sc into the closing ch of next puff st, *ch 3, 3 sc into closing ch of next puff st; rep from * to last 2 sc, ch 2, dc in last sc, turn.

Row 9: Ch 1, sc in first dc, 2 sc in first ch-2 space, * sc in each of next 3 sc, 3 sc into next ch-3 space; rep from * to end, working last sc into third ch of ch-5 at end of row, turn.

Cont in eyelet strip patt as foll:

Row 10: Ch 3 (counts as dc), skip first sc, dc in each sc to end, turn.

Row 11: (eyelet row) Ch 3 (counts as hdc, ch 1), skip 1 dc, * hdc in next dc, ch 1, skip 1 dc; rep from *, end hdc in last dc, turn—73 ch-1 spaces.

Row 12: (inc row) Ch 3 (counts as dc), [dc in ch-1 space, dc in next hdc] 2 times, 2 dc in ch-1 space (for inc), *[dc in hdc, dc in ch-1 space] 4 times, dc in hdc, 2 dc in ch-1 space; rep from * 13 more times to end, ending last rep dc in ch-1 space instead of 2 dc, turn—160 dc, counting ch-3 at beg of row.

Cont in flower patt as foll:

Row 13: Ch 1, * sc in next st, ch 5, skip 4 sts, dc in next st, ch 3, skip 4 sts, double cluster-3 (see Stitch Guide) in next st, ch 3, skip 4 sts, dc in next st, ch 5, skip 4 sts; rep from *, ending last rep by working (skip 3 sts, sc) in last st (instead of skip 4 sts), turn.

Row 14: Ch 3, work cluster-3 (see Stitch Guide) in second ch of ch-5 at end of Row 13, *ch 3, work another cluster-3 in the top of the cluster-3 just completed, dc in dc, ch 3, sc in ch-3 space at center of double cluster-3, ch 3, dc in dc, ch 3, work cluster-3 in first ch of ch-3 just completed, work cluster-3 in fourth ch of ch-5, skip the next [ch-1, sc, ch-1] group of sts, work cluster-3 in second ch of next ch-5; rep from * to end, omitting the final skip [ch-1, sc, ch-1] of last rep, turn.

Row 15: Ch 3, work cluster-3 in top of cluster-3, *ch 3, dc in dc, ch 5, sc in sc, ch 5, dc in dc, ch 3, double cluster-3 in center of paired cluster-3 of Row 14; rep from * 6 more times, ch 3, dc in dc, ch 5, sc in sc, ch

5, dc in dc, ch 3, cluster-3 in top of cluster-3, turn.

Row 16: *Ch 3, dc in dc, ch 3, cluster-3 in first ch of ch-3 just completed, work cluster-3 in fourth ch of ch-5, skip [ch-1, sc, ch-1], work cluster-3 in second ch of next ch-5, ch 3, work cluster-3 in first ch of ch-3 just completed, dc in dc, ch 3, dc2tog in top of double cluster-3 of Row 15; rep from * 7 more times, ending last rep with dc in top of cluster-3 instead of dc2tog, turn.

Row 17: Ch 3, dc in dc, *ch 5, dc in dc, ch 3, double cluster-3 in center of paired cluster-3 of Row 16, ch 3, dc in dc, ch 5, sc in sc; rep from * 7 times, ending last rep by working sc into last st, turn.

Row 18: Ch 6, sc in dc, *[ch 3, sc in top of cluster-3] 2 times, ch 3, sc in dc, [ch 5, sc in next st] 2 times; rep from * 6 more times, [ch 3, sc in top of cluster-3] 2 times, ch 3, sc in dc, ch 5, sc in last st, turn.

Row 19: Ch 1, work sc in each st, 3 sc in ch-3, and 5 sc in each ch-5 across, turn.

Row 20: Ch 2, *skip 1 st, hdc in next st, ch 1; rep from *, end hdc in last st, turn.

Row 21: Ch 1, skipping all hdc, work 2 sc in each ch-1 space, turn.

Row 22: (picot row) Ch 3, sl st in first st, *sl st in each of next 3 sts, ch 3, sl st in same st as last sl st; rep from * to end.

Fasten off.

FINISHING:

Neck trim: Rejoin yarn to top of right front opening and beg by working into the free loop of the beginning ch at neck edge.

Row 1: (RS) Sc in first st, ch 2, skip 2 sts (forms buttonhole), sc in each of next 82 sts—85 sts, counting the ch-2 as 2 sts, turn.

Row 2: Ch 2, working in front loops only, hdc in each of next 6 sts, *skip 1 st, hdc in each of next 8 sts; rep from *, end skip 1 st, hdc in each of the last 6 sts, turn.

Row 3: (slightly shapes front neck) Ch 1, sl st over the first 5 sts, sc in back loops of next 7 sts, hdc in back loops of next 3 sts, dc in back loops to last 15 sts, hdc in back loops of next 3 sts, sc in back loops of next 7 sts, sl st to end, turn.

Row 4: (picot row) Ch 3, sl st in first st, *sl st in each of next 3 sts, ch 3, sl st in same st as last sl st; rep from * to end.

Fasten off.



Carol Kaplan

Right front edging: To straighten the front edges, join with sl st to lower right front corner and work as foll:

Row 1: Sc in first sc, [ch 2, skip a 1/2" (1.3-cm) space, sc in edge of piece] 16 times, turn.

Row 2: Ch 2, work 2 hdc in each ch-2 space, end hdc in last sc.

Fasten off.

Left front edging: Work as for right front edging. Weave in loose ends. Block lightly to measurements. Sew button opposite buttonhole. ❄

MARI LYNN PATRICK loves to combine textured patterns and interesting silhouettes in Baltimore, Maryland.



RISK-FREE TRIAL OFFER

interweave.com/go/kdiwk

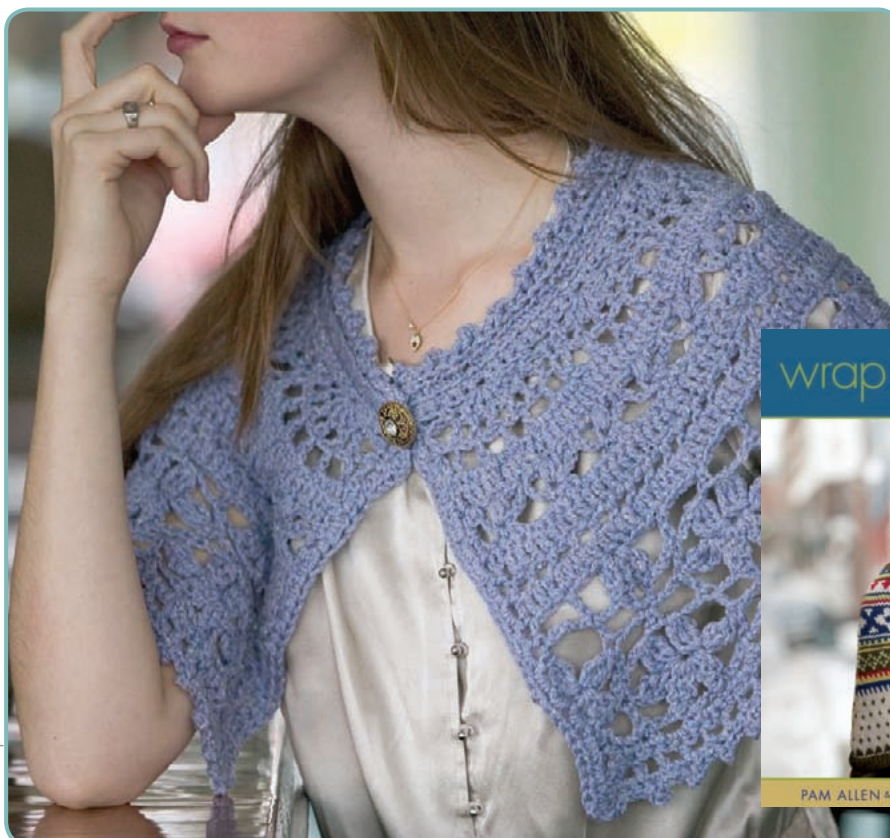

Carol Kaplan



PAM ALLEN + ANN BUDD | editors of INTERWEAVE KNITS

Excerpted with permission of the publisher for *Wrap Style* by Pam Allen and Ann Budd. Copyright 2005 Interweave Press, LLC. Not to be reprinted. All rights reserved.

Copyright Interweave Press LLC. Not to be reprinted. All rights reserved.